Classical Mechanics

Phy 235, Lecture 05.

Frank L. H. Wolfs
Department of Physics and Astronomy
University of Rochester

October 28, 2016.

The last KLM 747 landing on St. Maarten.



Non-linear oscillations.

- Linear differential equations:
 - Terms are proportional to acceleration, velocity, and position:

$$\frac{d^2y}{dx^2} + a \frac{dy}{dx} + by = f(x)$$

- Non-linear differential equations:
 - Include terms that non-linear in term of acceleration, velocity, and position.
- Non-linear terms are divided in two groups:
 - Symmetric around the equilibrium position. This requires terms proportional to εr^3 . If $\varepsilon > 0$: soft system. If $\varepsilon < 0$: hard system.
 - Asymmetric around the equilibrium position. This requires terms proportional to r^2 .

Non-linear Forces: ϵx^3 .

Symmetric potentials.

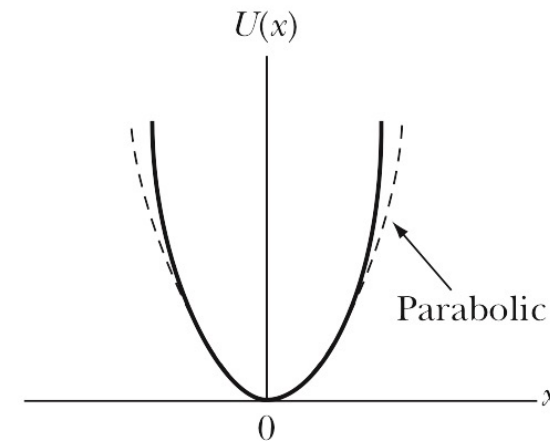
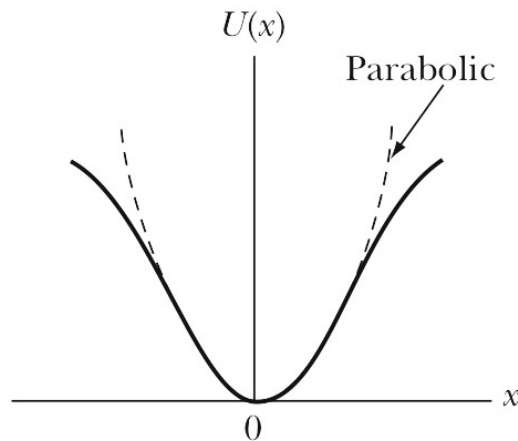
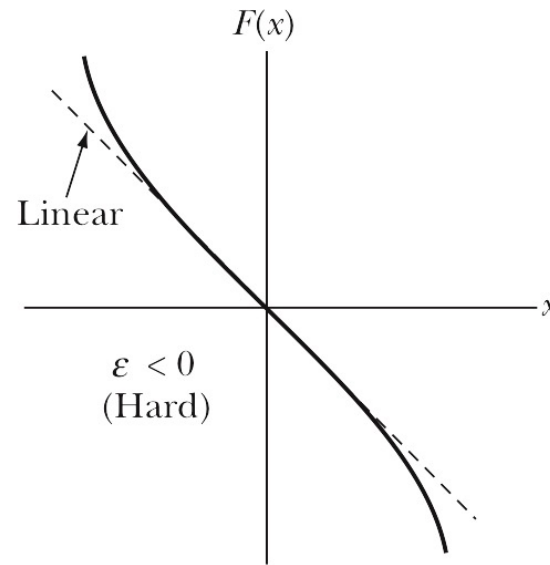
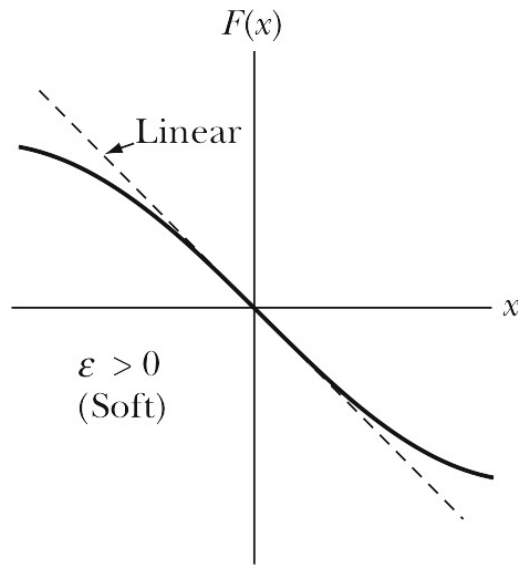

Non-linear Forces: λx^2 . Asymmetric potentials.

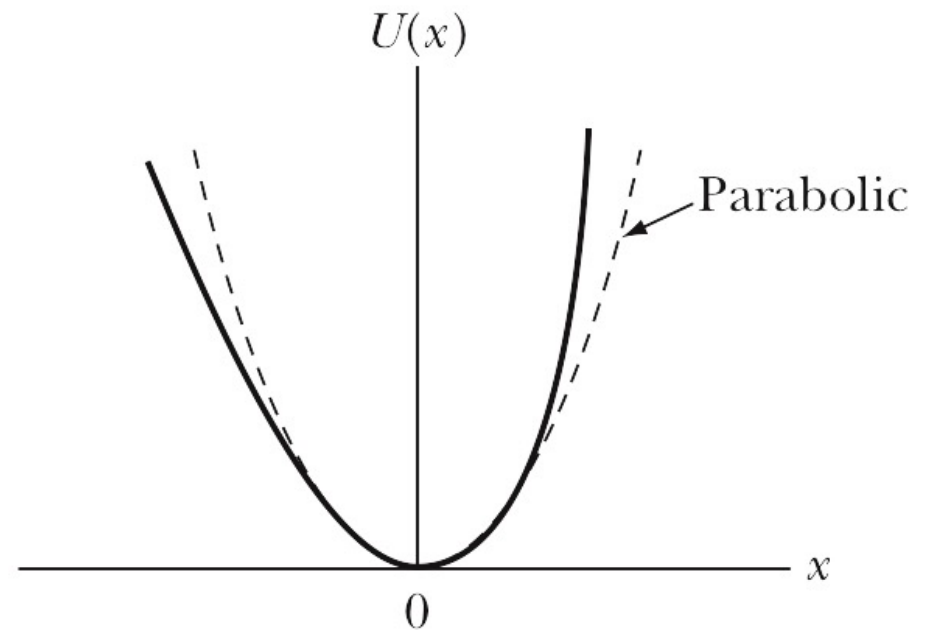
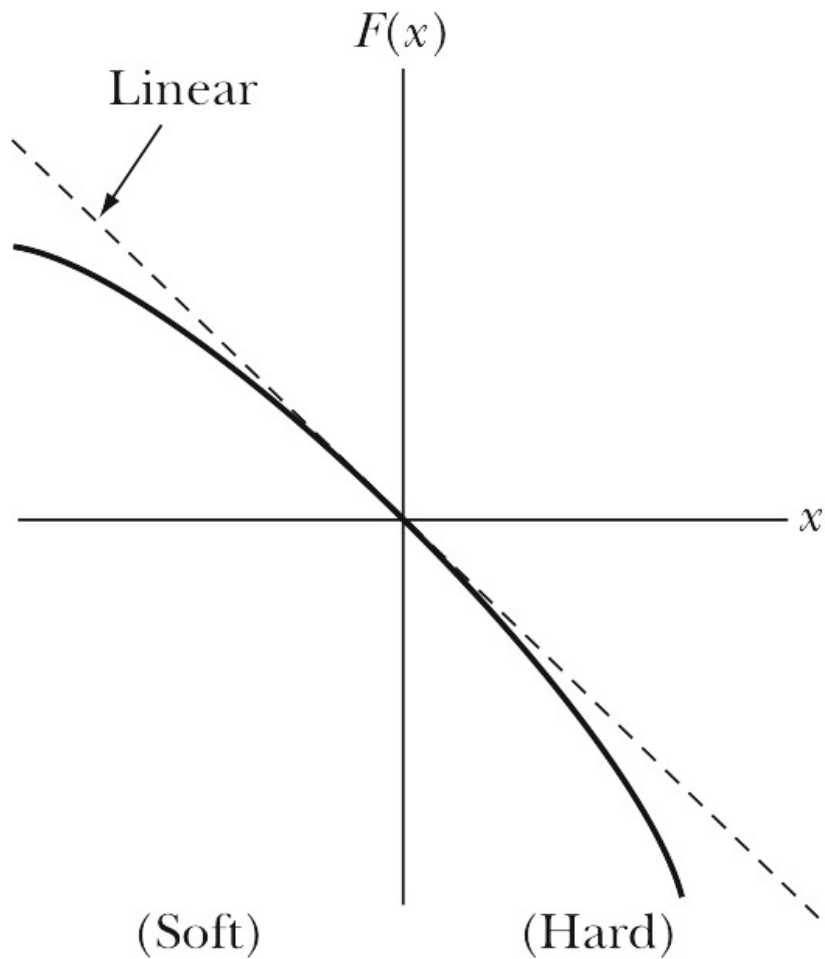

Numerical studies.

- Using tools such as VPython, it is easy to explore what happens when we add these additional components to the restoring force.
- Let us have a look:

<https://www.glowscript.org/#/user/wolfs/folder/Public/program/Phy235-HardandSoftMotionWithRadialPhasePlot>

Phase Diagrams.

Asymmetric for asymmetric potentials.

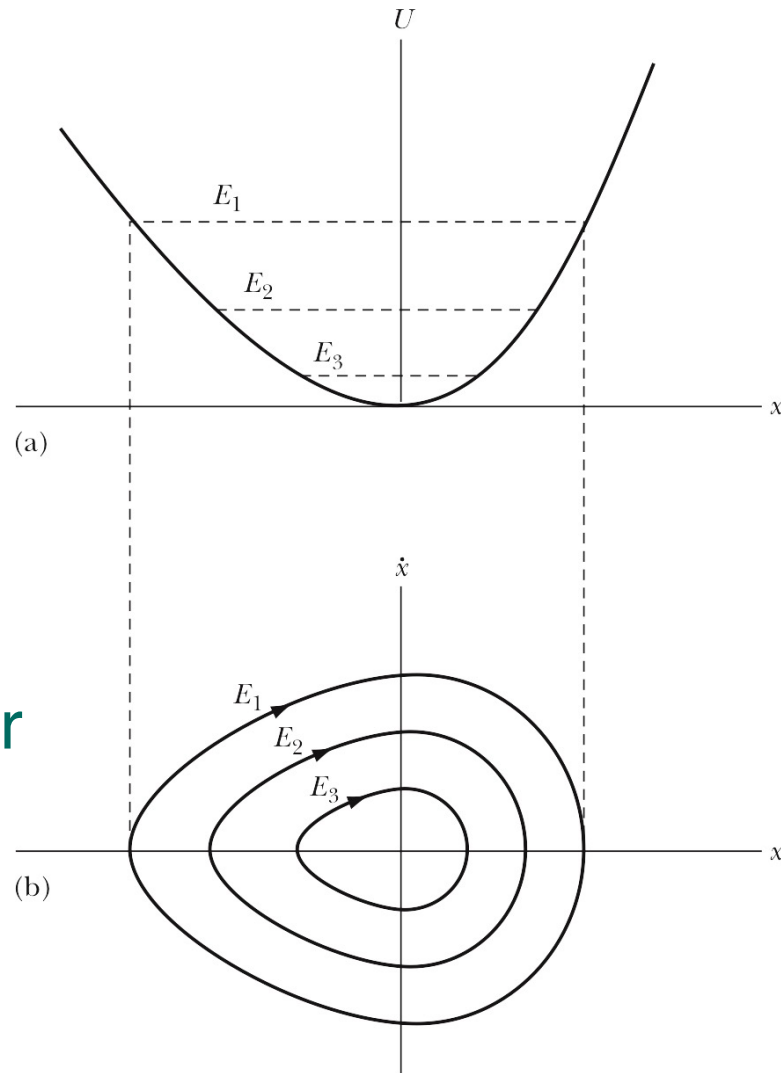

Closed contours for motion around stable equilibrium positions.

Phase diagrams.

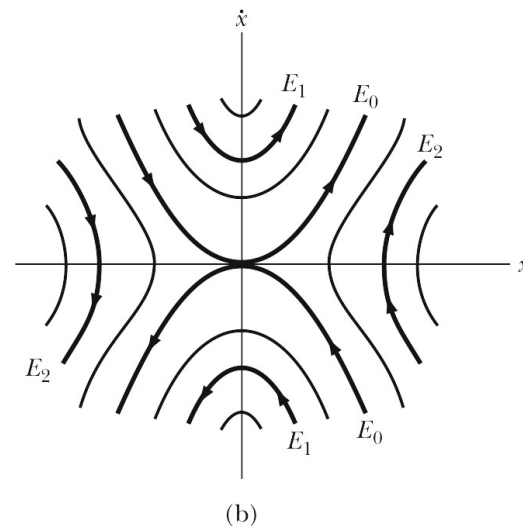
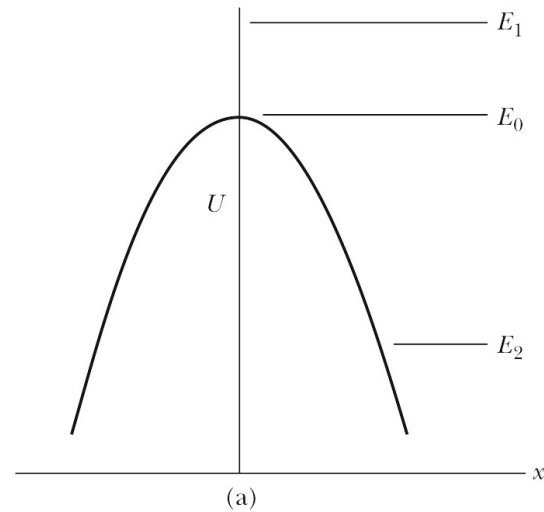

Open contours for motion around unstable equilibrium positions.

Van der Pol Equation.

- Used to describe non-linear oscillations in circuits containing vacuum tubes.
- Important facts:
 - Van der Pol was a Dutch physicist.
 - He studied physics in Utrecht and received his PhD in 1920.
- Other facts: de Van der Pol equation:

$$\ddot{x} + \mu(x^2 - a^2)\dot{x} + \omega^2 x = 0$$

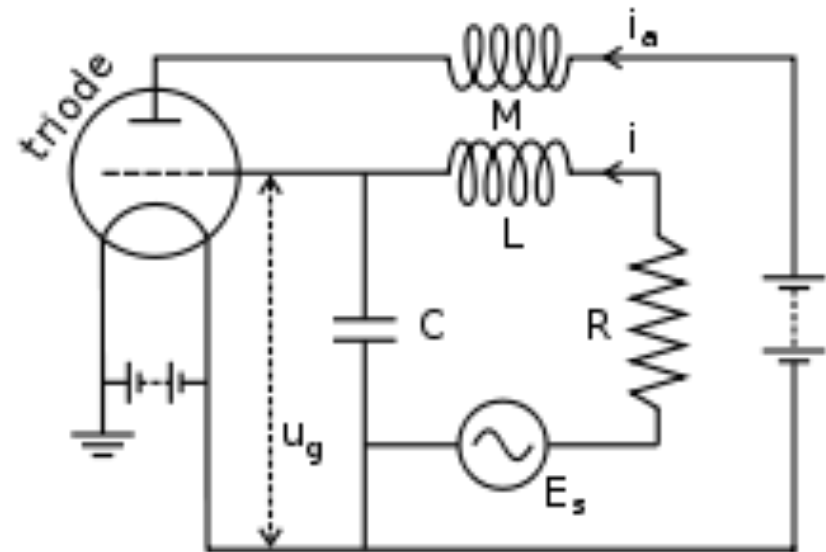

Using Mathematica to solve and display the solution of differential equations.

```
In[268]:= (* Set the values of the various parameters *)
```

```
mu = 0.05;
```

```
a = 1.0;
```

```
w0 = 1;
```

Initial parameters.

```
(* Solve the differential equations with the given set of initial conditions. *)
```

```
sol = NDSolve[
```

```
{x'[t] == v[t],
```

```
v'[t] == -mu * (x[t] * x[t] - a * a) * v[t] - w0 * w0 * x[t],
```

```
x[0] == 1,
```

```
v[0] == 0},
```

```
{x, v}, {t, 0, 50 * 2 * Pi}, MaxSteps -> 20 000];
```

Diff. equation.

Boundary conditions (x and v at $t = 0$).

```
(* Plot the solution of the differential equations *)
```

```
ParametricPlot[Evaluate[{x[t], v[t]} /. sol], {t, 0, 50 * 2 * Pi},
```

```
PlotRange -> All,
```

```
AxesLabel -> {"x (rad)", "v (rad/s)"}]
```

Display the solution.



3 Minute 52 Second Intermission.

- Since paying attention for 1 hour and 15 minutes is hard when the topic is physics, let's take a 3 minute 52 second intermission.
- You can:
 - Stretch out.
 - Talk to your neighbors.
 - Ask me a quick question.
 - Enjoy the fantastic music.

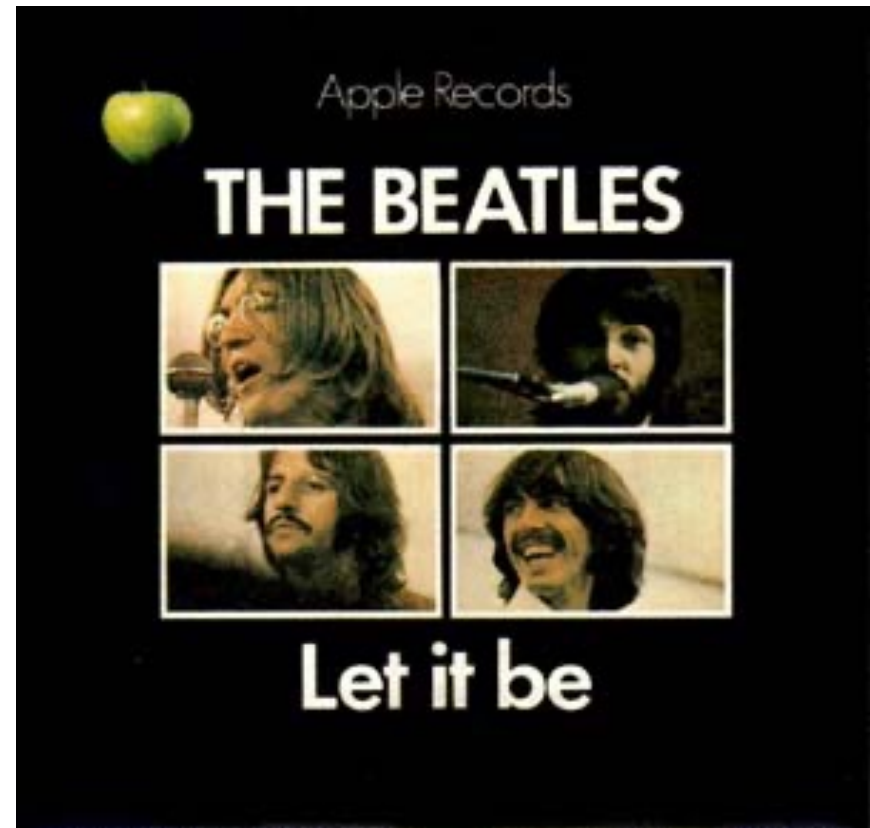

Plane Pendulum.

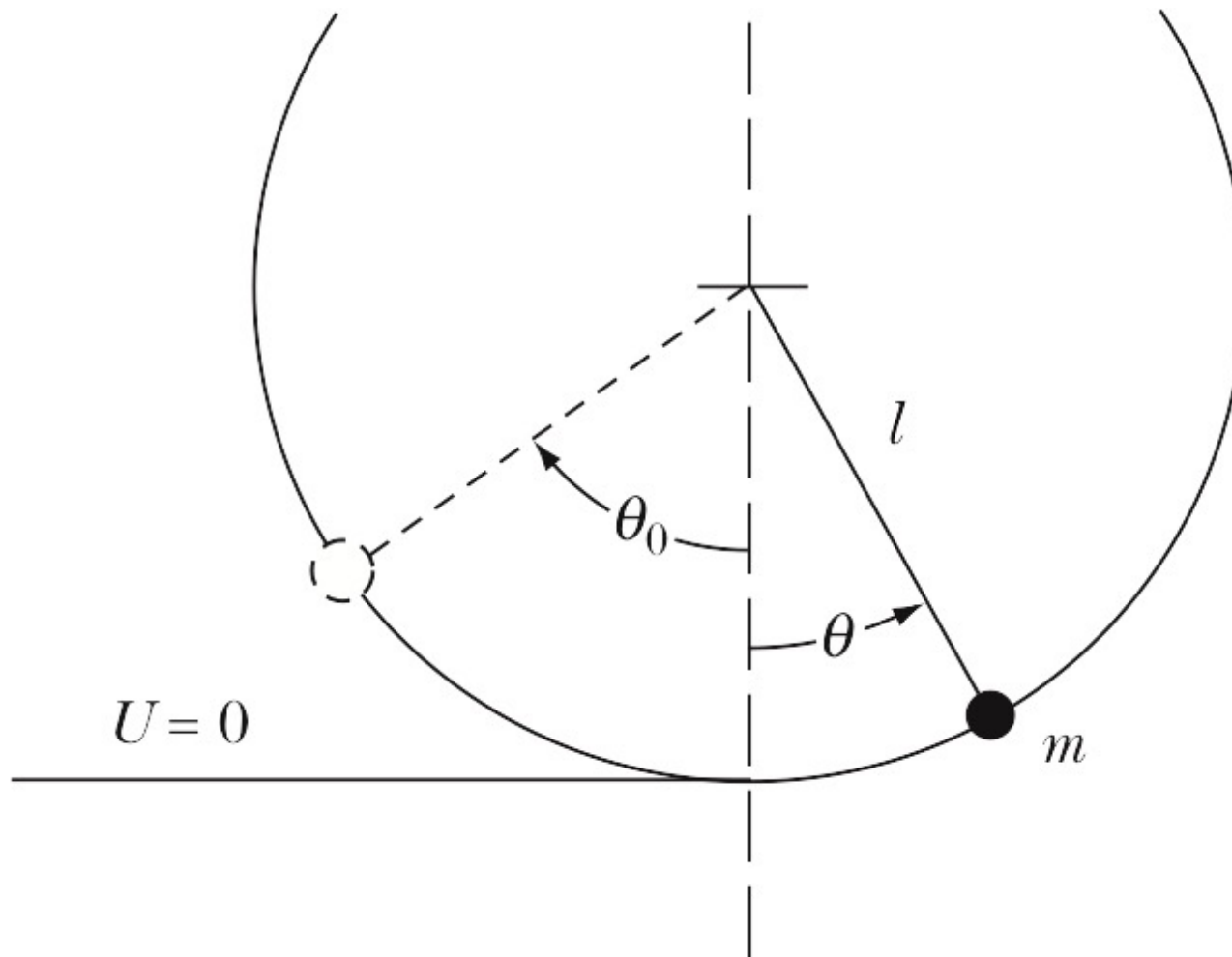

Plane Pendulum.

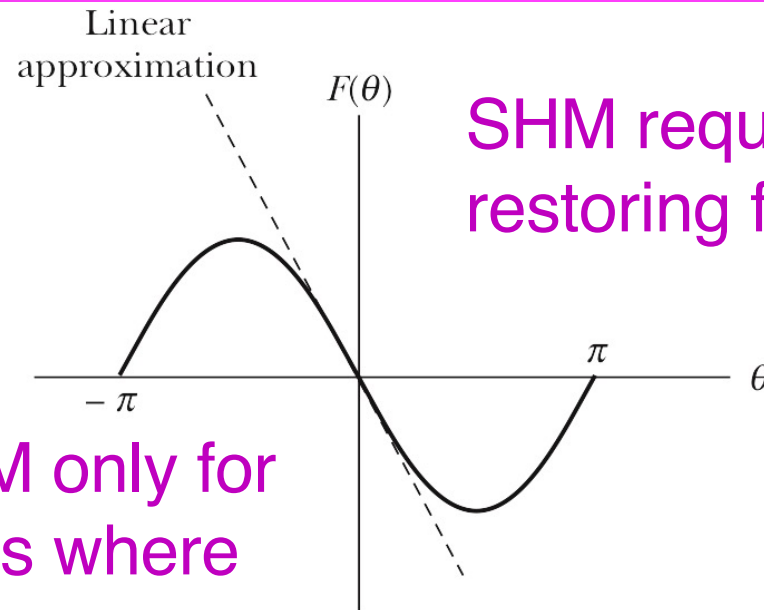

SHM requires a linear restoring force.

Expect SHM only for small angles where $\sin(\theta) = \theta$.

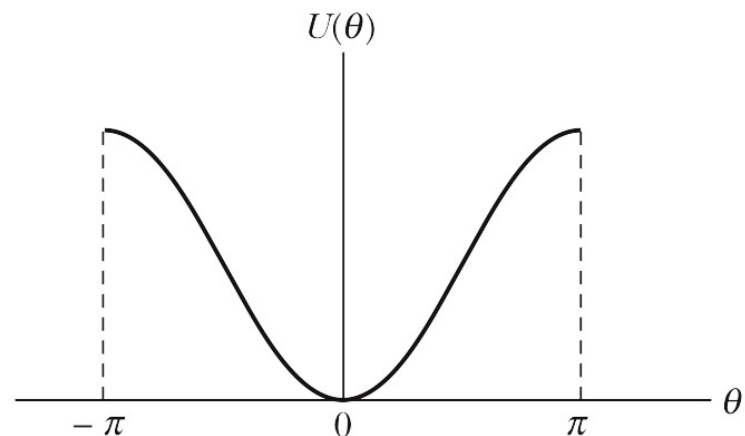

Numerical studies.

- Using tools such as VPython, it is easy to explore what happens for large angles.
- Let us have a look:

<https://www.glowscript.org/#/user/wolfs/folder/Public/program/Phy235-PlanePendulum>

Phase diagram for the plane pendulum.

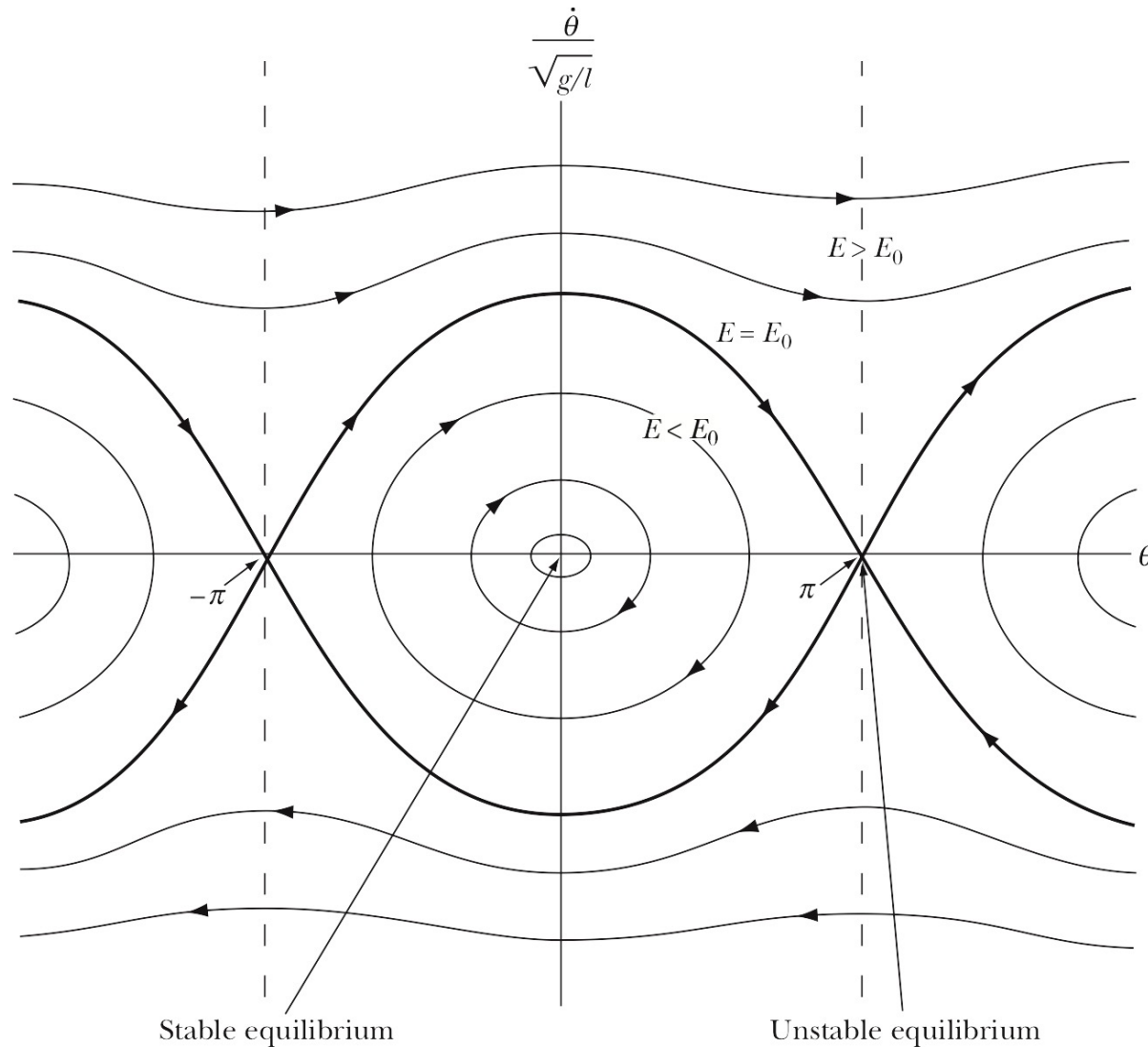

Problem 4.6.

- Derive the expression for the phase paths of the plane pendulum if the total energy $E > 2mgl$. Note that this is just the case of a particle moving in a periodic potential $U(\theta) = mgl(1 - \cos(\theta))$.

Problem 4.6.

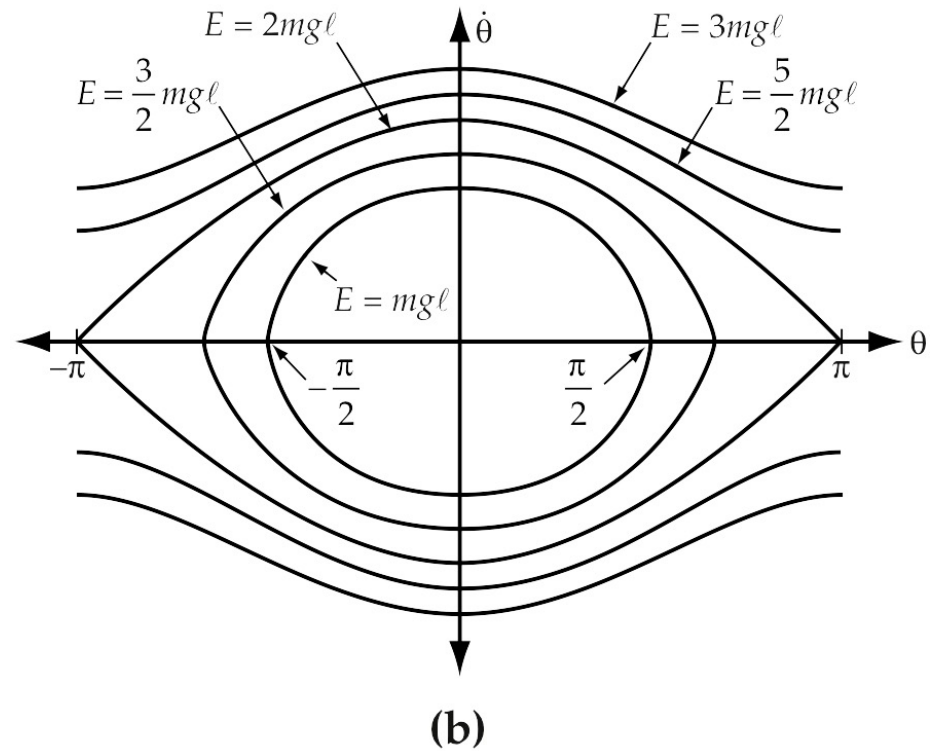
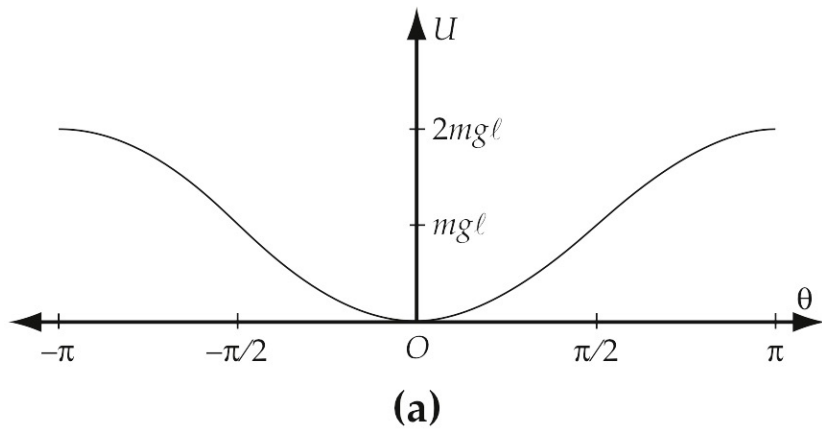

ENOUGH FOR TODAY?